

DOME



PROFESSIONAL



Last updated: 6 April 2021_V2.0

EV-DOME-SM-HEAD

FEATURES

- The Vandal Resistance Dome is a high impact (IK10) weatherproof Dome suitable for installations where protection against vandalism or tampering is required.
- High Quality Lithium batteries (**LiFePO₄**) and smart charger
- **Suitable for** Public amenities, Schools, Stadiums, Train stations, Car parks and Correctional facilities
- Fully compliant (**AS/NZS 2293**)



WEATHERPROOF

IP65 rated, suitable for demanding environments

D63

CLASSIFICATION

Light coverage for emergency light



VANDAL PROOF

IK10 impact rated, suited for exposed environments



DALI CERTIFIED

Connect to a DALI system for DALI testing

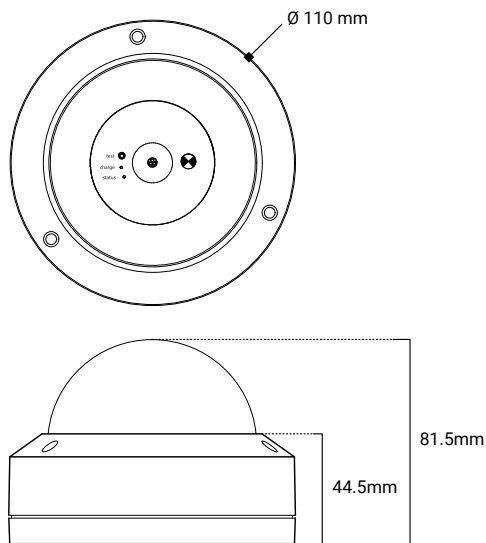

PRODUCT RANGE

ORDER CODE	PRODUCT NUMBER	SKU	QTY
EV-DOME-SM-HEAD			
Dome Surface Mount Emergency Luminaire for EV-LED-FIRE PRO – Head Only	9336462128008	12800	4
EV-LED-FIRE-PRO			
Pro Ledfire Emergency Luminaire, requires EV-DOME-SM-HEAD	9336462016947	01694	4
EV-LED-FIRE-PRO-LK			
Lynk Ledfire Professional Emergency Luminaire - w/wireless, requires EV-DOME-SM-HEAD	9336462102527	10252	4

GENERAL FEATURES

- Non-maintained operation
- Soft-start charger to reduce building load
- Lowest energy consumption (avg. <0.25W)
- Selectable discharge rating for hazardous areas
- Fast emergency switch-over (<0.5s) for high-task areas
- IK10 and IP65 rated

BUILT TO LAST

- Long life electronics
- 10 Years Design Life – 100,000 hours at max. ambient
- High Quality Lithium battery (LiFePO₄)

SUITABLE INSTALLATION TYPES (OUT OF THE BOX)

- Standalone (SPU)
- DALI (IEC62386)
- Ektor wired monitored system
- IEC62386 over IEC62386-104
- Wireless monitoring
- Self test (AS2293/ IEC62034)

ACCESSORY RANGE

ORDER CODE	DESCRIPTION
EV-3000MAH-6.4V-LIFEPO4	3000mAh 6.4V 2 Cell LiFePO ₄ Battery
EV-CMS-2.4M-5PIN	CMS 5 Pin Plug Set, 2.4M
EV-WAGO-2.4M-F&P	WAGO Plug 5-P Blue 51110475, 2.4M
EV-WIELAND-2.4M-F&P	Wieland Plug GST1815S B1 ZR1 S PB02, 2.4M
EV-WIREDBYCLICK-2.4M-F&P	Wire By Click 5-Pin Lead L1025/5, 2.4M
EV-CMS-2.4M-6PIN	CMS 6 Pin Plug Set, 2.4M

OPERATIONAL INFORMATION

GENERAL

Voltage	240V~ 50Hz
Ambient temp.	0 to 40°C
Class	2
IP rating	IP65
IK rating	IK10
Wiring	Flex and Plug
Mounting type	Surface Mount

EMERGENCY

Rated duration	90 / 120 min
Rated lumens	460 lm (2 hr)
Lamp power	4.3W
Classification	D63

BATTERY

Type	LiFePO ₄	Type	Smart charge
Voltage	6.4 V	Time	16 Hours
Codes	01303	Operation	Adjustable

CONSTRUCTION

Head	PC V0, 850 glow wire
Diffuser	PC V2, 750 glow wire
Cut out	Ø 92 mm

COMPLIANCE

Standards	AS/NZS 60598.2.22	IEC 62386-102	IEC 62034
	AS/NZS 2293.3	IEC 62386-202	CISPR 15
	IEC 60598-2-22		

NOTE: For more information on the chemical resistance of our polycarbonate or our compliance documentation, please see our website.

TOTAL POWER CONSUMPTION (TPC)

MAX.	AVG.
3 W	< 0.25 W

NOTE: Average power consumption calculated with the assumption of four emergency events per year and that the battery charger is in standby at all other times (above typical usage).

SPACING TABLE (D63 - 0.2 LUX)

2005

MOUNTING HEIGHT (M)							
2.1	2.4	2.7	3	3.3	3.6	4	4.5
19.4	20.3	21.1	21.8	22.4	23.0	23.7	24.5
5	6	7	8	9	10	15	20
25.2	26.4	27.4	28.1	28.6	28.9	28.0	22.5

ektor.com.au

 E: sales@evolt.com.au
 P: 1300 4EVOLT (438 658)

Ektor is dedicated to continuous product improvement. Datasheet is subject to change without notice, E&OE. Images are for illustrative purposes only.