

11258 EV-MERCURY-BASIC

Remove the product from the box and inspect it for any damage. If you believe the product to be damaged or otherwise unsound, DO NOT install the product. Please pack it back into its box and return it to the place of purchase for replacement. If the product is satisfactory, proceed with the installation.

INSTALLATION

Remove the cover using a flat blade screwdriver, release the clip by pushing in and down. The top cover can then be removed by sliding it away from the screwdriver. The cover **MUST BE** mounted prior to attaching to the body.

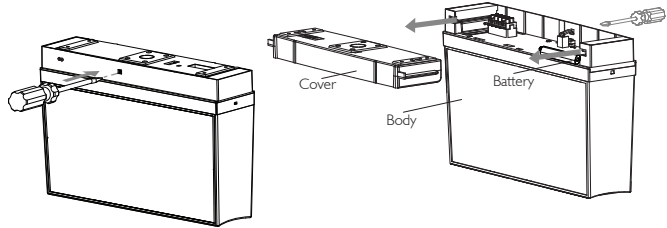

MOUNTING

Mount cover and connect wiring to terminals.

Assemble the product by sliding the body into place

For more mounting options, see our website at: ektor.com.au/11258

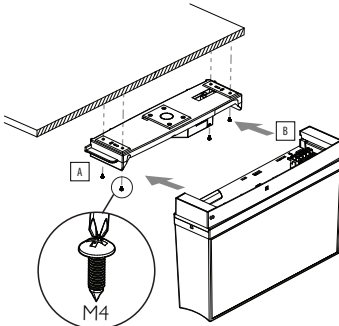

NON-MAINTAINED / MAINTAINED

MAINTAINED

LED is ON in normal and emergency operation

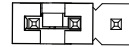

NON-MAINTAINED

LED is only ON in emergency

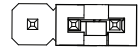

TERMINAL BLOCK

Wiring schematic for the terminal block used with the Mercury Basic.

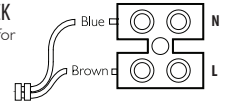

REPLACING THE BATTERY

Access the battery by removing the product cover. Disconnect and remove battery. Replace battery as was previously installed. Battery can be connected in one direction only, do not force. Allow a minimum 24 hours charging time before carrying out any discharge tests as per the requirements in AS/NZS 2293.

WARNING

The Ektor Mercury Basic Emergency Luminaire is connected to an unswitched active during normal operating conditions. When disconnected from the mains supply, the Mercury Basic is powered by a LiFePO4 battery operated inverter. Due to this, care should be taken when replacing the battery.

SAFETY WARNINGS

1. THIS PRODUCT MUST ONLY BE INSTALLED BY A LICENSED ELECTRICIAN.
2. BEFORE COMMENCING INSTALLATION TURN OFF AND ISOLATE THE ELECTRICAL SUPPLY.
3. RISK OF ACCIDENTAL CONTACT WITH LIVE PARTS. DO NOT ENERGISE WITH PRODUCT OPEN OR DISASSEMBLED.
4. SUPPLY VOLTAGES WITHIN PRODUCT. ISOLATE SUPPLY VOLTAGES BEFORE OPENING OR SERVICING.
5. THIS LUMINAIRE IS NOT INTENDED FOR USE IN HIGH-RISK TASK AREA LIGHTING.
6. MAINS SUPPLY AND BATTERY CIRCUIT SEPARATED BY REINFORCED INSULATION.
7. THE ONLY USER SERVICEABLE / REPLACEABLE PART IS THE BATTERY PACK.
8. DO NOT ATTEMPT TO SERVICE OTHER PARTS OF THE FITTING AS THIS WILL VOID THE WARRANTY.
9. AS THE INSTALLER, IT IS YOUR RESPONSIBILITY TO ENSURE YOU COMPLY TO ALL RELEVANT BUILDING AND SAFETY CODES FOR EXAMPLE THE BCA, AS3000. REFER TO APPLICATION STANDARDS FOR THE RELEVANT RULES.

BATTERY LIFE

To maintain the economic life of this product it is required that the battery be discharged and recharged at least once every 6 months. The battery life can be reduced if the battery is not discharged as per the requirements of AS/NZS 2293 or an equivalent standard. Increasing the number of duration tests above that as defined in AS/NZS 2293 or an equivalent standard can have a positive effect on the battery performance as long as 12 discharge cycles per year is not exceeded. The recharging device will operate normally after removal of short circuit fault.

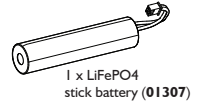

DIMENSIONS



Voltage (V)	230 V	Mounting Type	Rod / surface / suspended or wall mounted
Frequency (Hz)	50 Hz	Wiring	Terminal block (1 - 16mm □)
Ambient Temp. (°C)	0 - 40°C	Viewing Distance	24M
Class	2	Battery Type	LiFePO4 3.2V
Duration	90 / 120 min	Battery Supply Current	600mA
IP Rating	IP20 (IP65 case)	Charging Time	16 hours
Emergency Classification	C0:E2 C90:E1.6 (2Hr)	Charger Type	Variable
Average Power Consumption	2.2 W (Maintained)	Max Power Consumption	3.5 W (Maintained)

ORDERING INFORMATION

CODE	DESCRIPTION	PRODUCT NUMBER	CARTON QTY.	WEIGHT (NET/ GROSS)
11258	Mercury Basic Emergency Exit	9336462112588	4	1.1 Kg / 5.35 Kg

ACCESSORIES AND SPARE PARTS

CODE	DESCRIPTION	CODE	DESCRIPTION	CODE	DESCRIPTION
01995	Mercury III Decal pack	01915	Cantilever Bracket	01990	Rod Mount kit
03922	Weatherproof Case for Mercury III	01307	EV-1500mAh-3.2V-LiFePO4-Loom		

WARRANTY STATEMENT

Ektor products are distributed in Australia and New Zealand by Evolt Pty Ltd (Evolt). The Australian Consumer Law as well as other Australian laws guarantee certain conditions, warranties and undertakings, and give you other legal rights, in relation to the quality and fitness for purpose of Ektor products sold in Australia. In Australia, our goods come with guarantees that cannot be excluded under the Australian Consumer Law. You are entitled to a replacement or refund for a major failure and compensation for any other reasonably foreseeable loss or damage. You are also entitled to have the goods repaired or replaced if the goods fail to be of acceptable quality and the failure does not amount to a major failure. What constitutes a major failure is set out in the Australian Consumer Law. Nothing in this Warranty purports to modify or exclude the conditions, warranties and undertakings, and other legal rights, under the Australian Competition and Consumer Act and other Australian laws. Ektor products are warranted in Australia for a period of 12 months from the date of delivery of the product, provided that the products are properly stored, installed, used and maintained in accordance with the instructions contained within their manual. Products that have been altered in any way or used other than in accordance with their instructions are not covered by this warranty.

This warranty is not transferable and is valid only in the hands of the purchaser of the product. The warranty does not cover Ektor products other than those purchased from Evolt. Proof of purchase must be provided to Evolt with any warranty claim. Evolt recommends that the purchaser attaches their proof of purchase to their product manual. Evolt's total liability under this warranty is limited to the cost of repair or replacement of the faulty product. Evolt may satisfy its obligations under this warranty in full by repair or replacement of a faulty product. This warranty does not apply to consumable items such as lamps or batteries or other items that can be classified as consumable. For the avoidance of any doubt, any and all warranties or conditions which are not guaranteed under the Australian Competition and Consumer Act or the Australian Competition and Consumer Regulations 2010 and which are not expressly included in this Warranty as additional warranties or conditions are excluded. This Warranty does not cover loss or damage caused by wear and tear, misuse, incorrect installation or operation, failure to clean and maintain, incorrect voltage or non-authorized electrical connections, adverse external conditions (such as power surges and dips, acts of God, exposure to heat, corrosion, insect or vermin infestation), use of non-authorized or defective parts or globes, or to items that have been repaired other than by Evolt or a repairer approved by Evolt.

TECHNICAL SUPPORT AND TROUBLESHOOTING

For further assistance in using this product, consult your nearest wholesaler or Evolt Pty Limited.